

# Empower a Way of Collaboration with iPECS UC Solution

**iPECS**  
Your Communications Solution

 100 – 300 Ext. |

 Education |

 iPECS-LIK |



St Francis Xavier



## About the client

St Francis Xavier (SFX) is a London based Sixth Form College with a approximately 1300 learners.

The college has been rated as 'Outstanding' by Ofsted.

[www.sfx.ac.uk](http://www.sfx.ac.uk)

## Summary

This College with a reputation for excellence required a phone system that could bring them in to the present day with features such as IP technology, mobile working and call reporting, which was provided by the iPECS-LIK.

## Challenge

With 160 users, St Francis Xavier had a comprehensive list of requirements for their communications, not least of which was a solution that had a solid road map for the future and one that took advantage of recent developments such as IP telephony.

St Francis Xavier were very keen to use the existing cabling from their data network to minimize disruptions and reduce installation costs, while providing users with hot desking functionality and allowing users the flexibility to work remotely when needed.

The last major requirement was a comprehensive call logging and call reporting solution so that the College could keep on top of their communications usage at all times.

## Products

### System

- iPECS-LIK

### Terminal

- LIP-8000 Series
- IP DECT

### Application

- iPECS UCS Desktop client
- Voicemail to e-mail



## Delivering Future-ready Technology

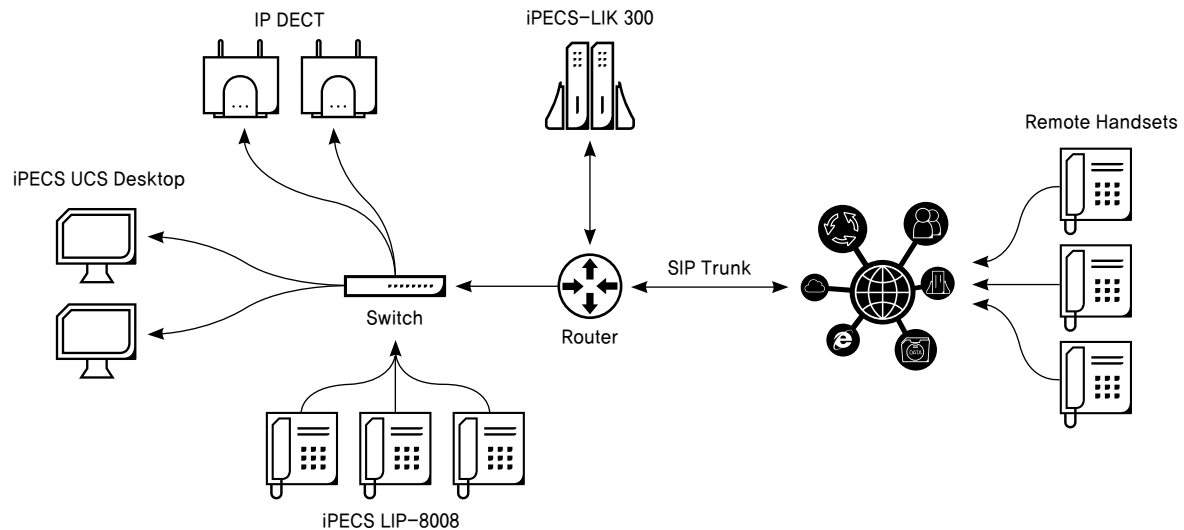

### Solution

The supplier chose the reliable and scalable iPECS-LIK as it catered for all of the College's current needs, while also giving them the flexibility they wanted to grow in the future.

Accompanying the telephone system were 120 of the latest IP telephone handsets, an easy to use screen based controller for the reception, as well as a gateway for 32 analogue or IP DECT phones for areas where there were no existing data cables.

Provision was also made for 10 remote workers to access the system at any one time using soft client technology on any PC connected to the Internet.

### Benefits

Thanks to the iPECS, St Frances Xavier now have a feature-rich communication system which has transformed the way they communicate and collaborate. The Reception Console has provided the front desk with greater visibility of incoming calls and the ability to quickly and easily transfer calls to the right department.

The ability to offer staff the option for remote working has helped with not only productivity but also staff happiness and retention. iCall Suite call reporting has enabled the College to better monitor their communications usage and stay on top of costs. Moreover, the iPECS-LIK has provided the college with the capacity they will need to grow in the future.